

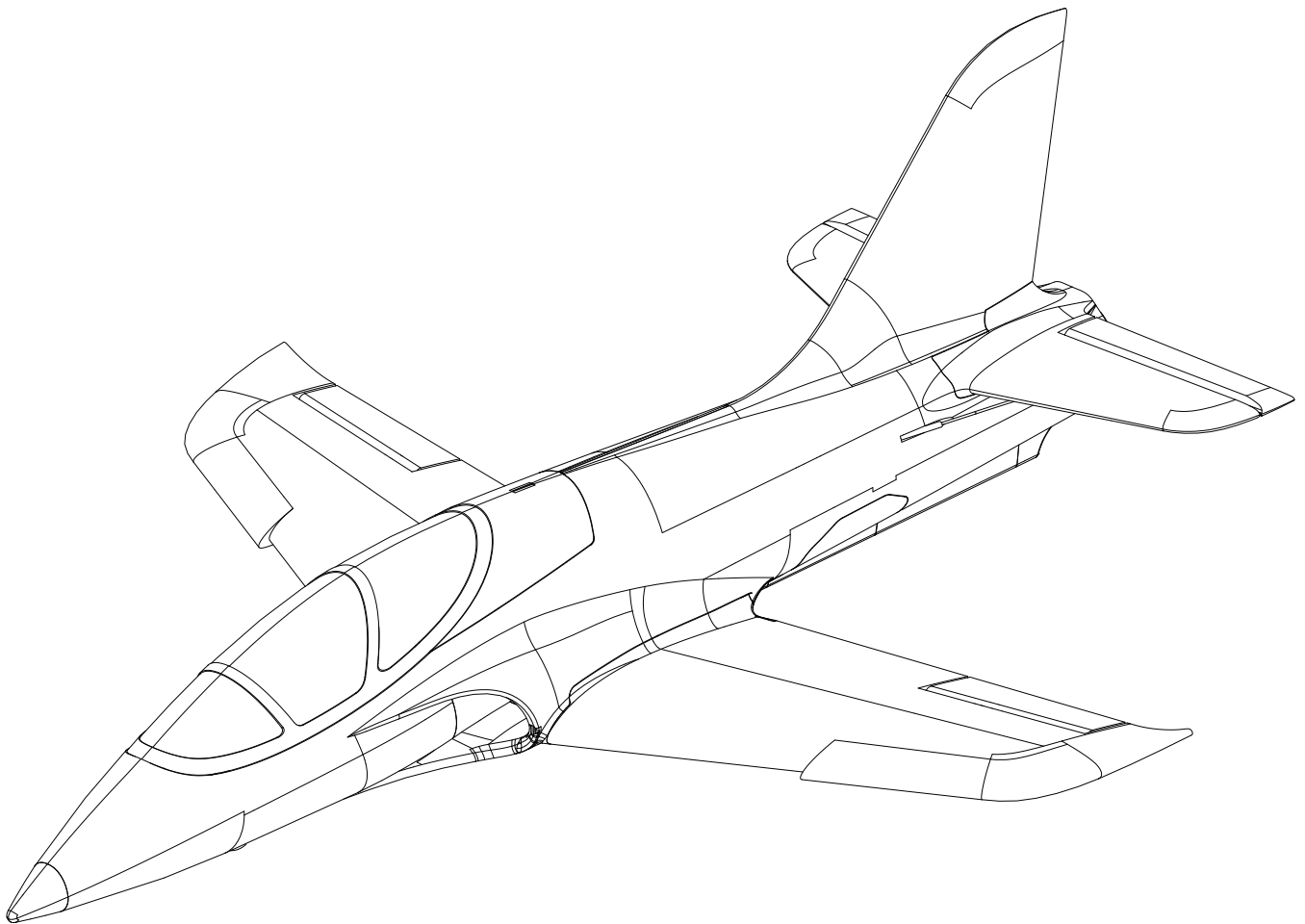

www.arrows-hobby.net

50mm Avanti Operating Manual



www.arrows-hobby.net

WARNING: This manual contains important information that will help you maintain and operate your model aircraft in a reliable and safe manner. Please read the instructions and warnings carefully prior to assembly, setup or use.

As this model aircraft is a sophisticated hobby product, it must be flown with safety and common sense in mind, failure in doing so may result in injury or property damage. This product is not intended for use by children without direct adult supervision.

Safety precautions and Warnings

As the user, you are solely responsible for the safe operation and maintenance of this product. Follow the directions and warnings listed in this manual, as well as that of supporting equipment (chargers, batteries etc.) and always use common sense.

This is not a toy. Not for children under 14 years of age.

- ★ Always operate your model in an open area away from buildings, cars, traffic or people. Never operate near people-especially children who can wander unpredictably. Never operate in populated areas for any reason, where injury or damage can occur.
- ★ Always keep a safe distance in all directions around your model to avoid collisions or injury. This model is controlled by a radio signal subject to interference from many sources outside your control. Interference can cause momentary loss of control.
- ★ Never catch the aircraft while it is in flight, the structure of the fuselage was not designed and protected for this purpose.
- ★ Never operate your model in bad weather, including in excessively windy or precipitating conditions.
- ★ Never operate your model with low transmitter batteries.
- ★ Keep your throttle quadrant in its lowest position prior and after every flight. Use the throttle cut function if able.
- ★ Always use fully charged batteries and move batteries before disassembly.
- ★ Avoid water exposure to all equipment not specifically designed and protected for this purpose.
- ★ Avoid cleaning this product with chemicals.
- ★ Never lick or place any part of your model in your mouth as it could cause serious injury or even death.
- ★ Keep all chemicals, small parts and anything electrical out of the reach of children.

Introduction

The Chinese transliteration of "Avanti" is āfántí. In the well-known story, āfántí is a fearless wise man who always goes forward bravely. He is humorous, optimistic and approachable, riding a donkey to outwit the story's antagonist, Master Bai. In the field of model aircraft, the name "Avanti" comes from Italian, and its meaning also happens to be "going forward."

Jets are generally faster and harder to fly than most propeller-driven aircrafts, making them difficult for inexperienced pilots to fly. The licensed Arrows Avanti is exactly what the name 'Avanti' stands for, giving inexperienced pilots the confidence to 'go forward'.

The integrated main wing & tail effectively improve the low-speed handling of the aircraft, significantly lowering the technical requirements. The small-scale size (airframe length 750mm, wingspan 640mm) reduces the site requirements, allowing pilots to take off and land at more sites away from crowds and buildings.

The Avanti, like other Arrows Hobby small-scale jets, comes without any landing gear to deal with, for higher speed and better vertical performance. But rest assured, the anti-friction plate and servo housing at the bottom of the fuselage help with this approach. Power comes courtesy of a 50mm 11 blade fan unit, 2627- 4500KV brushless motor and a high performance 30A ESC (with 3A BEC), compatible with extremely common 3S batteries - giving unparalleled speed and sound.

This Avanti will help you to cross over to the land of RC jets and fight one Master Bai after another.

Features:

- Powerful 2627- 4500KV brushless motor;
- Highly efficient 50mm 11 bladed EDF unit;
- Reliable, high-performance 30A ESC with 3A BEC;
- Easy to hand-launch and belly-land, without any landing gear to deal with;
- Simple lightweight design for extended flight times;
- Highly attractive trim scheme;
- PNP with Vector system-allowing three flying modes;
- Uncompromising performance despite its friendly price;
- Licensed by Sebart, Italy.

Table of contents

| | |
|-------------------------------------------|---|
| Introduction | 3 |
| Specifications | 3 |
| Kit contents | 3 |
| Model Assembly | 4 |
| Battery installation | 5 |
| Receiver diagram | 5 |
| Preflight check | 5 |
| Clevis installation | 6 |
| Control horn and servo arm settings | 7 |
| Center of gravity(CG) | 7 |
| Before flying the model | 7 |
| Flying course | 8 |
| Trouble shooting | 9 |
| Spare parts list content | 9 |

Specifications

| | |
|----------------------------|------------------------------------------------------|
| Wingspan | 640mm(25.2in) |
| Overall length | 750mm(29.5in) |
| Flying weight | ~ 460g |
| Motor size | Brushless2627-KV4500 |
| Wing load | 51.7g/dm² (0.11oz/in²) |
| Wing area | 8.9dm² (137 sq.in²) |
| ESC | 30A |
| Servo | 9g*3 |
| Recommended battery | 11.1V 1300mAh 30C |

Kit contents

Before assembly, please inspect the contents of the kit. The photo below details the contents of the kit with labels. If any parts are missing or defective, please identify the name or part number (refer to the spare parts list near the end of the manual) then contact your local shop.

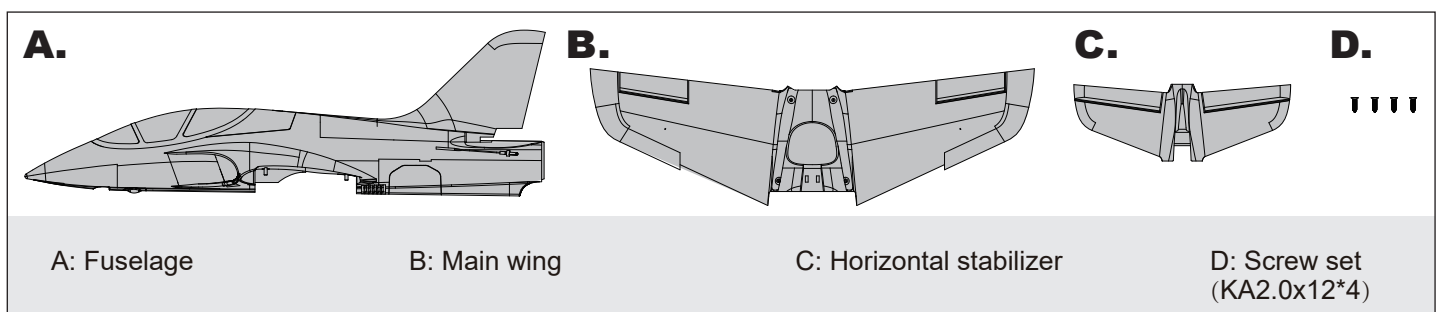

Installation of the horizontal stabilizer and pushrod

1. Apply foam safe glue to the area of horizontal stabilizer and rear fuselage shown in the figure, then slide the horizontal stabilizer to fuselage and fix in place.

2. With the servo centered, attach the pushrod clevis to the elevator control horn.

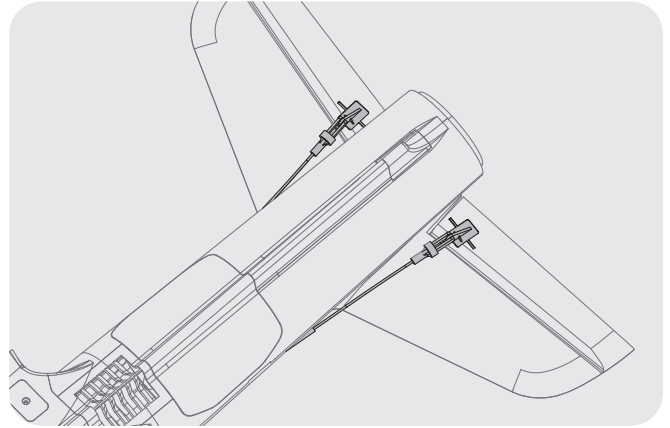
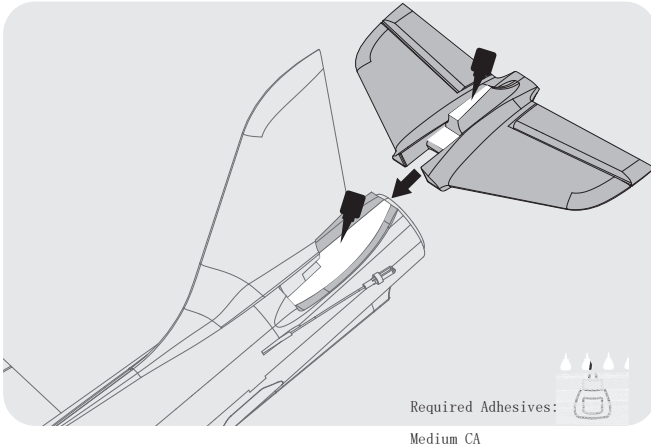

Mainwing installation

1. Apply main wing onto fuselage.
2. Fix the mainwing onto fuselage using the included screws.
3. Connect aileron servo leads to Y harness as shown.

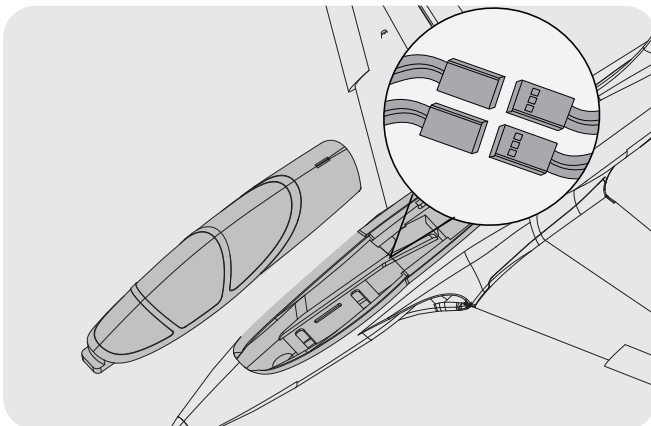
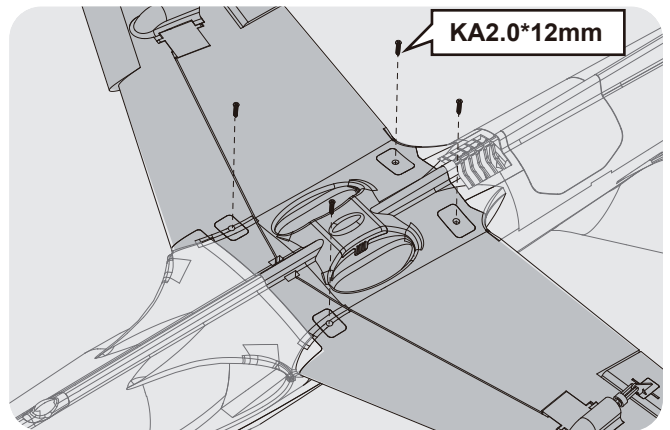
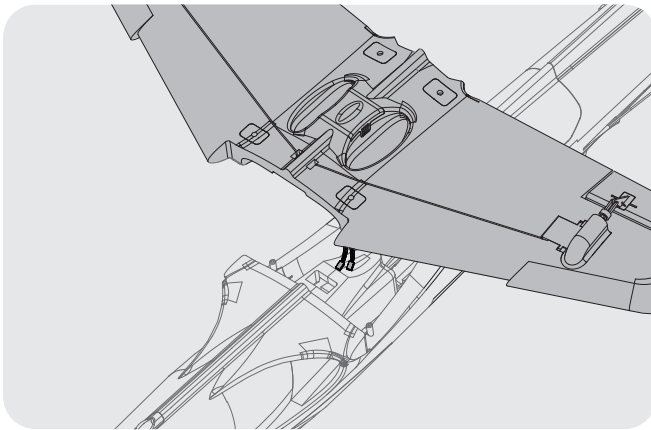

«—— Battery installation

1. Remove the battery hatch.
2. Remove the hook and loop tape from the fuselage. Apply the looped surface to the battery.
3. Install the battery into the fuselage- securing it with the preinstalled battery straps.

Note: The dimension of the battery compartment is 160x40x40mm. The weight of each battery may vary due to different manufacturing techniques. Move the battery fore or aft to achieve the optimal center of gravity.

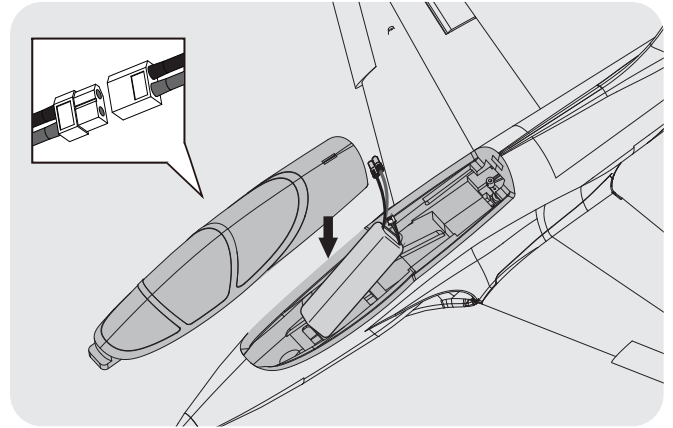

Receiver diagram

The cables from the servo connector board should be connected to your receiver in the order shown. Note that the LEDs (if any) can be powered by any spare channel on the receiver.

Tuck the wire leads into the recessed cavity towards the rear of the battery hatch.

| | | Receiver |
|-----------------|---|-----------------------------|
| Aileron | 1 | Channel-1 — Aile |
| Elevator | 2 | Channel-2 — Elev |
| Throttle | 3 | Channel-3 — Thro |
| Rudder | 4 | Channel-4 — Rudd |
| Spare | 5 | Channel-5 — Spare |
| Spare | 6 | Channel-6 — Spare |

«—— Preflight check

Important ESC and model information

1. The ESC included with the model has a safe start. If the motor battery is connected to the ESC and the throttle stick is not in the low throttle or off position, the motor will not start until the throttle stick is moved to the low throttle or off position. Once the throttle stick is moved to the low throttle or off position, the motor will emit a series of beeps. Several beeps with the same tune means the ESC has detected the cells of the battery. The count of the beeps equals the cells of the battery. The motor is now armed and will start when the throttle is moved.
2. The motor and ESC come pre-connected and the motor rotation should be correct. If for any reason the motor is rotating in the wrong direction, simply reverse two of the three motor wires to change the direction of rotation.
3. The motor has an optional brake setting. The ESC comes with brake switched off and we recommend that the model be flown with the brake off. However, the brake could be accidentally switched on if the motor battery is connected to the ESC while the throttle stick is set at full throttle. To switch the brake off, move the throttle stick to full throttle and plug in the motor battery. The motor will beep one time. Move the throttle stick to low throttle or the off position. The motor is ready to run and the brake will be switched off.
4. Battery Selection and Installation. We recommend the 11.1V 1300mAh 30C Li-Po battery. If using another battery, the battery must be at least a 11.1V 1300mAh 30C battery. Your battery should be approximately the same capacity, dimension and weight as the 11.1V 1300mAh 30C Li-Po battery to fit the fuselage without changing the center of gravity significantly.



transmitter and model setup

After assembly and prior to your first flight, make sure all control surfaces respond correctly to your transmitter by referring to the diagram below.

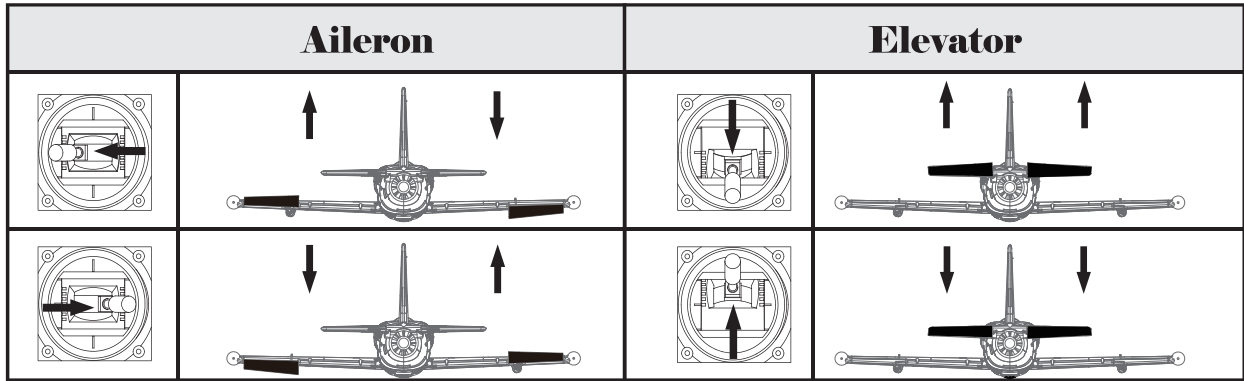

Control throws

The suggested control throw setting for the 50mm Avanti are as follows (dual rate setting):

Tips: The maiden flight should always be flown using low rates, fly the aircraft until you are familiar with its characteristics prior to trying high rates. Make sure the aircraft is flying at a decent altitude and speed prior to using high rates, as the aircraft will be sensitive to control inputs with the larger control surface movements.

| | High Rate | Low Rate |
|-----------------|----------------|---------------|
| Elevator | 10mm up / down | 8mm up / down |
| Aileron | 10mm up / down | 8mm up / down |

« Clevis installation



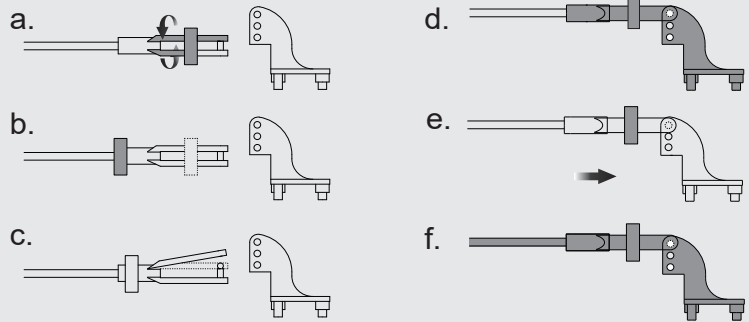

1. Pull the tube from the clevis to the linkage.
2. Carefully spread the clevis, then insert the clevis pin into the desired hole in the control horn.
3. Move the tube to hold the clevis on the control horn.

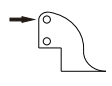

Control horn and servo arm settings

1. The table shows the factory settings for the control horns and servo arms. Fly the aircraft at the factory settings before making changes.

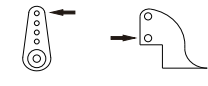
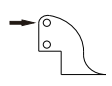
2. After flying, you may choose to adjust the linkage positions for the desired control response.

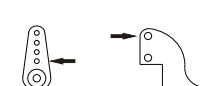
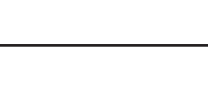
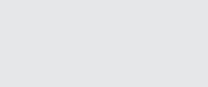
| | Horns | Arms | More control throw |
|----------|-----------------------------------------------------------------------------------|-------------------------------------------------------------------------------------|-------------------------------------------------------------------------------------|
| Elevator |  |  |  |
| Ailerons |  |  |  |
| | | | Less control throw |
| | | |  |
| | | |  |

Finding the center of gravity

Finding the correct center of gravity is critical in ensuring that the aircraft performs in a stable and responsive manner. Please adjust the weight distribution so the aircraft balances in the range stated on the diagram.

- Depending on the capacity and weight of your chosen flight batteries, move the battery forward or backward to adjust the center of gravity.
- If you cannot obtain the recommended CG by moving the battery to a suitable location, you can also install a counterweight to achieve correct CG. However, with the recommended battery size, a counterweight is not required. We recommend flying without unnecessary counterweight.

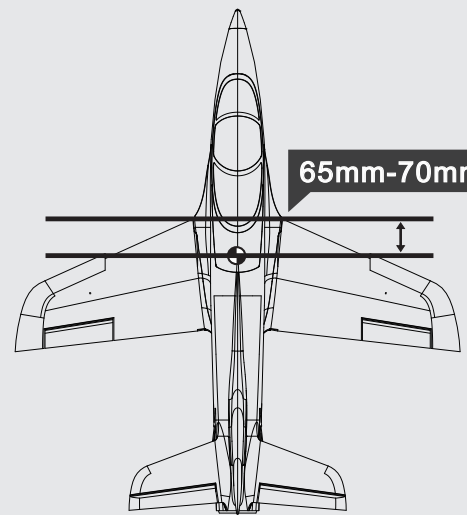

Before flying the model

Find a suitable flying site

Find a flying site clear of buildings, trees, power lines and other obstructions. Until you know how much area will be required and have mastered flying your plane in confined spaces, choose a site which is at least the size of two to three football fields - a flying field specifically for R/C planes is best. Never fly near people - especially children, who can wander unpredictably.

Performing a range check

A radio range check should be performed prior to the first flight of the day. This test may assist you in detecting electronic problems that may lead to a loss of control- problems such as low transmitter batteries, defective or damaged radio components or radio interference. This usually requires an assistant and should be done at the flying site.

« — Before flying the model — »

Always turn your transmitter on first. Install a fully charged battery in the battery bay, then connect it to the ESC. In this process, make sure that the throttle cut functionality is on, and that the throttle stick is secured in its lowest position- otherwise, the propeller/fan will engage and possibly cause bodily harm.

Note: Please refer to your transmitter manual that came with your radio control system to perform a ground range check. If the controls are not working correctly or if anything seems wrong, do not fly the model until you correct the problem. Make certain all the servo wires are securely connected to the receiver and the transmitter batteries have a good connection.

Monitor your flight time

Monitor and limit your flight time using a timer (such as a stopwatch or on the transmitter, if available). As modern Lithium Polymer batteries are not designed to discharge completely, when the battery runs low, the ESC will lower then completely cut the power to the motors to protect the battery. Often (but not always) power can be briefly restored after the motor cuts off by holding the throttle stick all the way down for a few seconds. To avoid an unexpected dead-stick landing on your first flight, set your timer to a conservative 4 minutes. When your alarm sounds you should land right away.

— Flying course — »

Take off

Point the aircraft into the wind while slowly applying power until the aircraft starts to track straight, use the rudder when necessary. When the aircraft reaches takeoff speed, ease back on the elevator stick until the aircraft is climbing at a constant rate without decelerating. Climbing at too steep of an angle at the relatively low speeds of a takeoff-climb may result in an aerodynamic stall.

Flying

Always choose a wide-open space for flying your plane. It is ideal for you to fly at a sanctioned flying field. If you are not flying at an approved site always avoid flying near houses, trees, wires and buildings. You should also be careful to avoid flying in areas where there are many people, such as busy parks, schoolyards, or soccer fields. Consult laws and ordinances before choosing a location to fly your aircraft. After takeoff, gain some altitude. Climb to a safe height before trying technical manoeuvres.

Landing

Land the aircraft when you start to feel sluggish motor response. If using a transmitter with a timer, set the timer so you have enough flight time to make several landing approaches. The model's three point landing gear allows the model to land on hard surfaces. Align model directly into the wind and fly down to the ground. Fly the airplane down to the ground using 1/4-1/3 throttle to keep enough energy for proper flare. Before the model touches down, always fully decrease the throttle to avoid damaging the propeller or other components. The key to a great landing is to manage the power and elevator all the way to the ground and set down lightly on the main landing gear. With some practice, you will be able to set the aircraft gently on its main gear and hold it that way until the speed reduces enough where the nose wheel (tricycle landing gear aircraft) or tail wheel (tail draggers) settles onto the ground.

Maintenance

Repairs to the foam should be made with foam safe adhesives such as hot glue, foam safe CA, and 5min epoxy. When parts are not repairable, see the spare parts list for ordering by item number. Always check to make sure all screws on the aircraft are tightened. Pay special attention to make sure the spinner is firmly in place before every flight.

« Troubleshooting

| Problem | Possible Cause | Solution |
|---------------------------------------------------------------------------|-----------------------------------------------------------------------------------------------------------------------------------------------------------------------------------------------|----------------------------------------------------------------------------------------------------------------------------------------------------------------------------------------------------------------------------|
| Aircraft will not respond to the throttle but responds to other controls. | <ul style="list-style-type: none"> • ESC is not armed. • Throttle channel is reversed. | <ul style="list-style-type: none"> • Lower throttle stick and throttle trim to lowest settings. • Reverse throttle channel on transmitter. |
| Excessive vibration or propeller noise. | <ul style="list-style-type: none"> • Damaged spinner, propeller, motor or motor mount. • Loose propeller and spinner parts. • Propeller installed backwards. | <ul style="list-style-type: none"> • Replace damaged parts. • Tighten parts for propeller adapter, propeller and spinner. • Remove and install propeller correctly. |
| Reduced flight time or aircraft underpowered. | <ul style="list-style-type: none"> • Flight battery charge is low. • Propeller installed backward. • Flight battery damaged. | <ul style="list-style-type: none"> • Completely recharge flight battery. • Replace flight battery and follow flight battery instructions. |
| Control surfaces unresponsive or sluggish. | <ul style="list-style-type: none"> • Control surface, control horn, linkage or servo damage. • Wire damaged or connections loose. | <ul style="list-style-type: none"> • Replace or repair damaged parts and adjust controls. • Do a check of connections for loose wiring. |
| Controls reversed. | <ul style="list-style-type: none"> • Channels are reversed in the transmitter. | <ul style="list-style-type: none"> • Do the control direction test and adjust controls for aircraft and transmitter. |
| Motor loses power Motor power pulses then motor loses power. | <ul style="list-style-type: none"> • Damage to motor, or battery. • Loss of power to aircraft. • ESC uses default soft Low Voltage Cutoff(LVC). | <ul style="list-style-type: none"> • Do a check of batteries, transmitter, receiver, ESC, motor and wiring for damage(replace as needed). • Land aircraft immediately and recharge flight battery. |
| LED on receiver flashes slowly. | <ul style="list-style-type: none"> • Power loss to receiver. | <ul style="list-style-type: none"> • Check connection from ESC to receiver. • Check servos for damage. • Check linkages for binding. |

» Spare parts list

| | | | |
|---------|------------------------------|------------|------------------------------------|
| AHRA101 | Fuselage | AHDFX002 | 50mm 11 Blade Ducted Fan w/o motor |
| AHRA102 | Mainwing set | AHEDF002 | 50mm 11 Blade Ducted Fan w/ motor |
| AHRA103 | Horizontal stabilizer | AHSFB002 | 50mm Fan Blade |
| AHRA104 | Canopy | AHSDX002 | 50mm Single Duct |
| AHRA105 | Ducted fan cover | AHKVX4500 | 2627-KV4500 motor |
| AHRA106 | Linkage Rods | AHESC003 | 30A ESC |
| AHRA107 | Screw Set | AHSER003 | 9g servo positive |
| AHRA108 | Control arms | VEC-AH026P | Integrated Gyro |
| AHRA109 | Control arm cover | | |
| AHRA110 | Anti Friction Parts for Nose | | |
| AHRA111 | Anti Friction Parts for Tail | | |
| AHRA112 | Anti Friction Parts for Wing | | |
| AHRA113 | Sticker | | |

重要提示：

1. 在组装、调整及飞行前请务必认真阅读产品说明书以熟知产品的特性。请严格按照说明书提示进行飞机的组装、调整及飞行。
2. 模型不是玩具，具有一定的危险性，操作者需要具备一定的飞行经验，初学者请在专业人士指导下操作。
3. 禁止十四岁以下儿童在任何情况下操作、飞行。

警告

- ★作为用户，您对本产品的安全操作和维护负全部责任。请始终严格遵照产品指导说明及安全警告操作本产品及其相关配置（例如遥控器、充电器、电池等）。
- ★本产品由无线电遥控器控制，在飞行过程中，可能会受到外界强信号源干扰而导致失控，甚至坠机，因此在飞行过程中务必始终与飞机保持一定的安全距离，避免意外碰撞、受伤。
- ★请勿随意暴露置放模型飞机的电子产品，尤其是电池，存放时请务必保证周围三米之内无易燃易爆物体。
- ★在任何情况下，都务必保证油门杆处于起始位、发射机处于通电状态时，才能连接模型飞机内部的动力电池。
- ★在任何情况下，都不要尝试用手去回收飞行中的模型飞机，必须要等模型飞机降落停稳以后，再进行回收。
- ★请勿在公路、人群、高压线密集区、机场附近及其它法律法规明确禁止飞行的场合飞行。
- ★请勿在雷雨、大风、大雪或者其它恶劣气象环境下飞行。
- ★请勿将相关化工类产品、零部件、电子部件等置于儿童可触及的范围。
- ★请勿将本产品尤其是未经特别设计和保护的电子件暴露于潮湿的环境中，以免造成损坏。
- ★请勿将本品任意处置于口中，以免造成人身伤亡。
- ★请勿在发射机电池低电量的情况下操纵模型飞机。
- ★请勿在配件未充分冷却的情况下触碰或移动。
- ★请勿使用化学制剂擦拭清洁本产品。
- ★务必保证飞机在整个操作过程中始终在视线范围和遥控控制距离内。
- ★务必保证在拆卸飞机之前移除电池。
- ★务必保证所使用的电池是满电状态。
- ★务必保证所使用的所有线束完好无损。

飞行前准备

1. 开箱检查包装内物品是否有损坏或遗漏。
2. 通读此飞机说明书以及其相关配置说明书（如遥控器、电池和充电器）。
3. 确保遥控器和使用的电池都是满电状态（请严格遵从配件原厂家说明书）。
4. 遥控器设置（请严格遵从遥控器厂家的说明书）。
5. 严格遵从本说明书指导组装飞机，确保螺丝、卡扣、夹头、插销等紧固件全部安装到位，舵角摇臂连接可靠。（暂不安装螺旋桨）。
6. 安装满电状态的电池，并通过挪动电池在电池舱里的前后位置，调整飞机重心（CG）至说明书推荐位置。
7. 通电测试确保所有的操纵钢丝活动自如。
8. 通电测试确保所有的舵面正确响应遥控器输入指令。
9. 根据所需调整舵面行程（首飞推荐使用出厂设置行程）。
10. 桨机安装螺旋桨，确保螺旋桨组件安装到位，且转动方向正确。
11. 寻找一个安全空旷远离建筑和人群的场地，根据场地实际情况，做具体飞行计划。

飞机简介

“阿凡提”在艾克拜尔吾拉木的故事里是个勇敢无畏勇往直前的智者形象，他幽默乐观、平易近人，骑着毛驴智斗“巴依老爷”。在航模领域，“阿凡提”直译自意大利语“Avanti”，而“Avanti”的中文意思恰巧就是前进。

众所周知，涵道机通常比大多数螺旋桨驱动的飞机飞行速度更快，飞行难度也更大，这使得初入门的飞行员很难驾驭涵道机。而 Arrows 阿凡提正如它的名字所代表的意思一样，给予经验匮乏的涵道机飞行员以“前进”的信心和底气。

Arrows 50mm 阿凡提整机的机翼（主翼和平尾）采用一体化设计，有效提高飞机的低速操控性，降低技术门槛。此外，小比例尺寸（机身长 750mm，翼展 640mm）降低了场地需求，使得飞行员可以在更多远离人群和建筑的场地起降。

阿凡提与 Arrows 前面几款小级别涵道机一样，没有收放，没有起落架，采用手抛起飞腹部着陆的起降方式，以获得更快的速度和更好的垂直性能——不必担心，机身底部的防擦片和防擦舵机壳给这种起降方式保驾护航。PNP 版本配备 2627-KV4500 无刷电机，50mm 11 叶涵道组，和高质量 30A 电调，兼容市面上绝大多数常见的 3S 锂电池，实现涵道机特有的速度和声浪。

你需要这架阿凡提去敲开涵道机世界的大门迎战一个又一个“巴依老爷”。

特征：

- 动力充沛的 2627-KV4500 电机；
- 高效率 50mm11 叶涵道组；
- 高性能的 30A 电调 内置 3A 开关 BEC，供电更充足，飞行更安全；
- 手抛起飞，机腹着陆；
- 轻量化设计，有效延长飞行时间；
- 极具辨识度的涂装；
- PNP 带唯翼飞控，三种模式自由切换；
- 高性价比；
- 意大利 Sebart 公司授权产品。

目录

| | |
|-----------------|----|
| 飞行前准备 | 10 |
| 目录 | 11 |
| 产品包装清单 | 11 |
| 飞机简介 | 11 |
| 产品基本参数 | 11 |
| 组装过程 | 12 |
| 电池安装 | 13 |
| 接收机连接示意图 | 13 |
| 重心 | 14 |
| 重要产品相关信息 | 14 |
| 电调说明 | 14 |
| 遥控器设置 | 15 |
| 舵面测试 | 15 |
| 夹头安装方式 | 15 |
| 舵角和舵机摇臂安装 | 15 |
| 舵面行程 | 15 |
| 故障检修指导 | 16 |
| 配件列表 | 16 |

产品基本参数

| | |
|------|------------------------|
| 机身长 | 750mm |
| 翼展 | 640mm |
| 飞行重量 | 大约 460 克 |
| 电机 | 无刷 2627-KV4500 |
| 翼载荷 | 51.7g/d m ² |
| 翼面积 | 8.9d m ² |
| 电调 | 30A |
| 舵机 | 9g Servo x 3 |
| 电池 | 11.1V 1300mAh 30C |

！注意：此处各项参数，均是使用本公司配件测试得出，如果使用他厂配件，会有所差异。使用他厂配件时所产生的问题，我司将无法给予技术支持。

产品包装清单

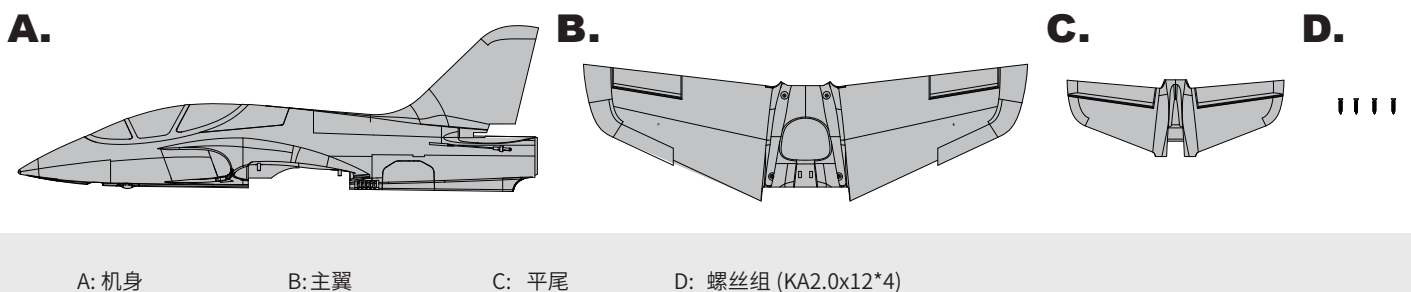

安装平尾和连接杆

1. 分别在机身尾部和平尾的图示位置图上泡沫胶，保持平尾舵面朝下，安装平尾至机身尾部槽位。
2. 保持舵机回中状态，将连接杆夹头安装到舵角上。

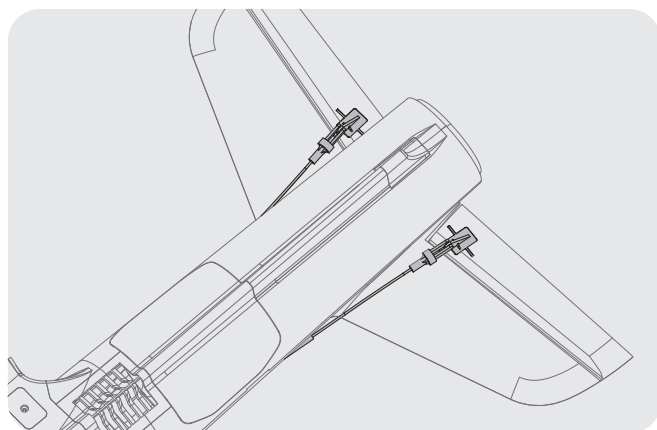
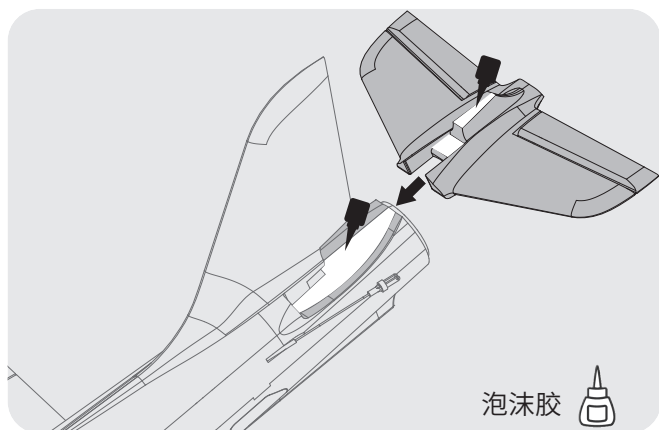

主翼安装

1. 如图所示，安装主翼至机身。
2. 使用附带的螺丝将主翼固定在机身上。
3. 连接副翼舵机线至 Y 线。

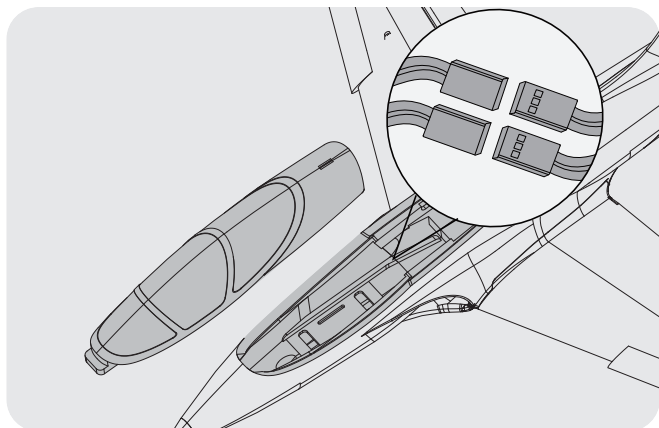
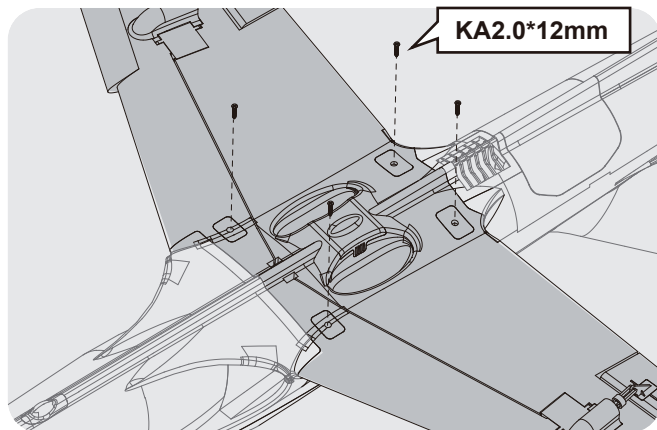
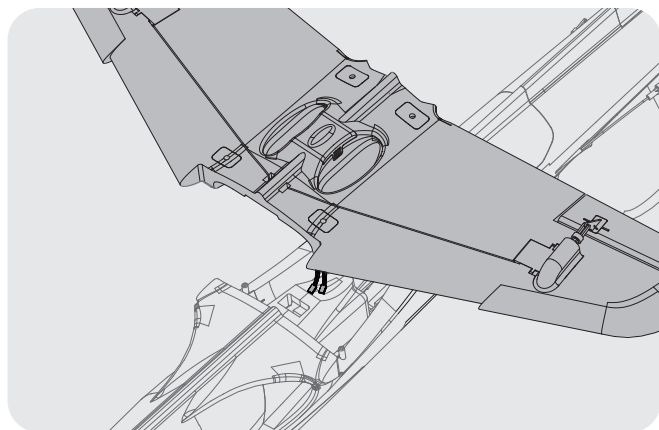

—— 电池安装 ——

如图所示，安装厂家推荐型号电池至电池舱，使用所附魔术带或魔术贴固定。

注意：

1. 电池与电调连接前，务必确定油门杆处于低位。
2. 启动油门前，务必确定没有任何人或物体处于螺旋桨的转动直径以内。
3. 由于不同电池厂家生产的电池重量有轻微差异，需要调整电池在舱内的前后位置来平衡飞机的重心位置。
4. 电池舱尺寸如下：160x40x40mm

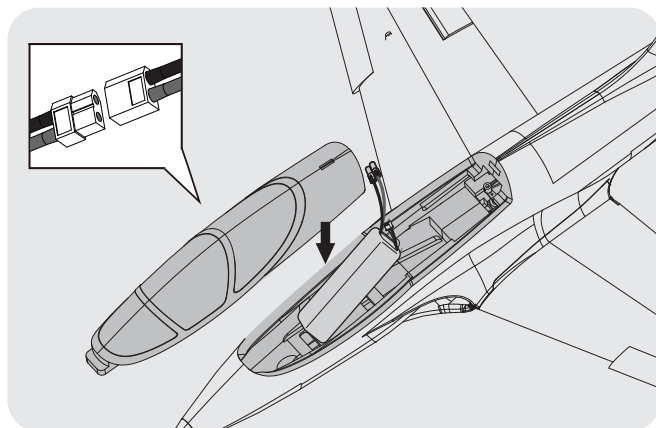

—— 接收机连接示意图 ——

以 Futaba 遥控器为例，请按照图示顺序一一连接接收机通道，其他通道可接入襟翼信号线或 LED 灯信号线，随后妥善固定接收机。

| | | Receiver |
|------|---|---------------------|
| 副翼 | 1 | Channel-1 —Aile |
| 平尾 | 2 | Channel-2 —Elev |
| 油门 | 3 | Channel-3 —Thro |
| 垂尾 | 4 | Channel-4 —Rudd |
| 起落架 | 5 | Channel-5 —Gear |
| 其他通道 | 6 | Channel-6 —Spare |

«—— 重心 ——

本产品的重心在机翼前缘向后 65-70mm 的位置。玩家需要通过移动电池在电池舱里的前后位置或者使用配重块来调整重心。请务必确保，在调整飞机重心的时候，飞机处于组装完毕待飞的状态。

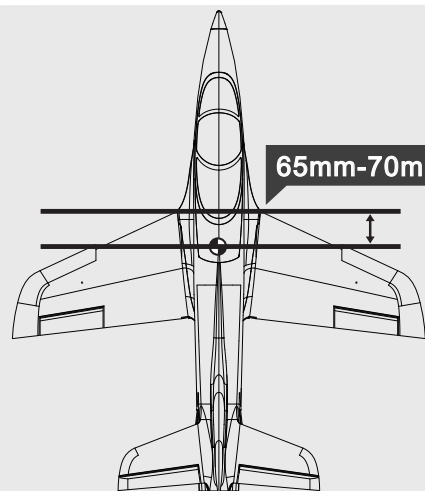

1. 本产品随附的电调处在安全启动模式。安全启动模式，意即如果电机、电池已连接至电调，但油门杆不在低油门位置或关闭位置，电机不会启动，只有将油门杆移至低油门位置或关闭位置，电机才会启动。油门杆移至低油门位置或关闭位置时，电机将发出一系列哔声。几声相同的哔声表示电调已检测到电池。哔声的数量等于电池的节数。此时，电机已准备就绪，并将随着油门移动开始启动。
2. 电机和电调已预连接，需要观察电机转动方向是否正确，如方向不正确，只需换插三条电机与电调连接线中的任意两条，即可改变电机转动方向。
3. 电机具有刹车设置（可选项）。由于电调是刹车关闭状态，我们推荐电机也保持刹车关闭状态。此外，请注意，当油门杆处在全油门位置上时，如果将电机、电池连接到电调，则可能会意外打开刹车。如要关闭刹车，需将油门杆移至全油门位置，并插上电机电池，电机此时会发出一声哔响，再将油门杆移至低油门位置或关闭位置，则电机已准备就绪，且刹车将被关闭。
4. 电池的选择和安装。我们推荐使用 11.1V 1300mAh 30C 锂电池。如果使用其他电池，电池的容量不能低于推荐电池容量，且电池的尺寸和重量应与推荐电池相同，以保证适配机身电池舱，且不会显著改变重心。

电调说明

注意: 为了让电调适应你的遥控器油门行程，在首次使用本电调或更换其他遥控器使用时，均应重新设定油门行程。

油门行程设定说明:

1. 开启遥控器，将油门打到最高点；
2. 将电调接上电池，等待 2 秒；
3. “哔 - 哔 -” 油门最高点，确认声音；
4. 将油门推到最低等待 1 秒；
5. N 声短鸣音表示锂电节数；
6. “哔 - ” 油门最低点，确认声音；
7. 系统准备就绪可以起飞。

正常使用开机过程说明:

1. 开启遥控器，将油门打到最低点；
2. 电调接上电池，鸣叫提示音符“123”，表示上电正常；
3. 发出 N 声短鸣音，表示锂电池节数；
4. 自检 OK，发出长鸣音“哔——”系统准备就绪；
5. 推油门可随时起飞。

舵面测试

在飞机组装完成以后，在计划飞行之前，需要使用遥控器测试每个舵面的工作情况，确保摇杆动作与各个舵面动作的对应关系如下图所示：

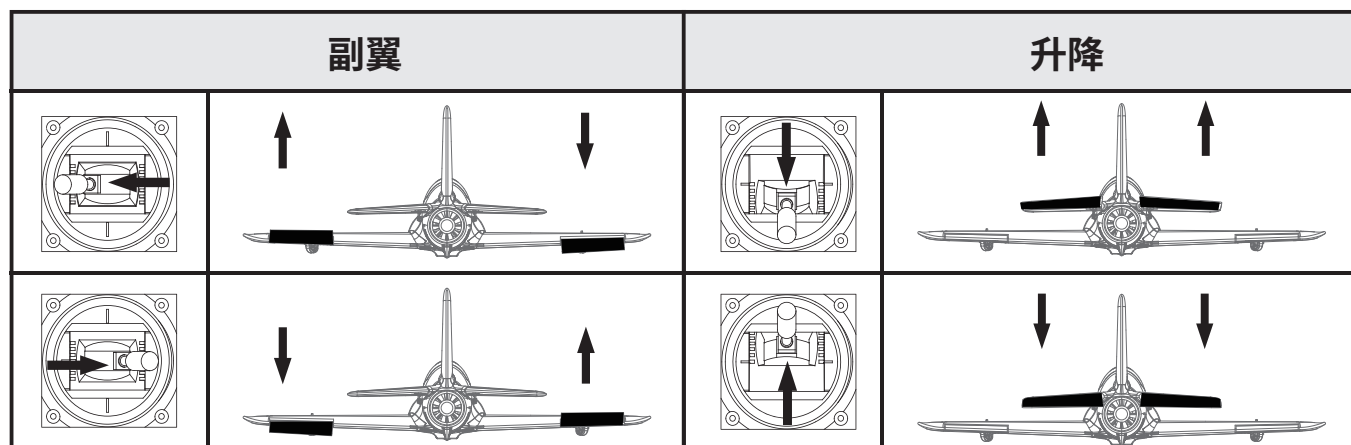

夹头安装方式

1. 保证舵机为回中状态，将连接杆夹头调整到合适位置。
2. 将 O 型圈移开，打开夹头，将夹头安装到舵角孔位。
3. 将 O 型圈移回相应位置，锁紧夹头。

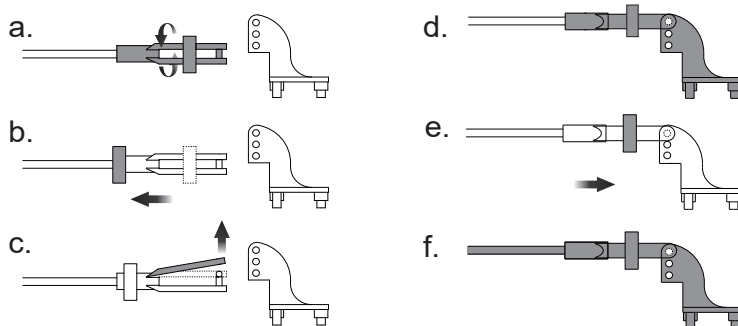

舵角和舵机摇臂安装

图示是出厂设置，首飞建议直接使用出厂设置，完成首飞以后，根据个人情况以及对模型飞机的熟知程度自行调整。

| | 舵角 | 摇臂 | 大舵面 |
|----|----|----|-----|
| 平尾 | | | |
| 副翼 | | | |
| | | | 小舵面 |
| | | | |

舵面行程

本产品舵面行程参数如右图所示：

请注意，舵量越大，模型飞机的动作响应越快，动作幅度越大。首飞建议使用小舵量。然后根据个人情况以及对模型飞机的熟知程度调整舵量。

| | 大 | 小 |
|-----|------------|-----------|
| 升降舵 | 10mm 上 / 下 | 8mm 上 / 下 |
| 副翼舵 | 10mm 上 / 下 | 8mm 上 / 下 |

遥控器设置

请参考遥控器原厂家说明书。

| 问题 | 问题原因 | 解决方式 |
|----------------|---------------------------------------------------------------------------------------------------------------------------------------------------|------------------------------------------------------------------------------------------------------------------------------------------------------|
| 油门推杆无响应，但舵机有响应 | <input checked="" type="checkbox"/> 电调未连接电机 <input checked="" type="checkbox"/> 油门通道反向 | <input checked="" type="checkbox"/> 降低油门推杆和油门微调设定 <input checked="" type="checkbox"/> 反过来重新装油门通道 |
| 桨的噪音过大或者震动过大 | <input checked="" type="checkbox"/> 桨罩、桨、电机、电机架坏了 <input checked="" type="checkbox"/> 桨或者桨罩的小部件松动了 <input checked="" type="checkbox"/> 桨装反了 | <input checked="" type="checkbox"/> 更换损坏的配件 <input checked="" type="checkbox"/> 把桨、桨夹和桨罩的小部件拧紧 <input checked="" type="checkbox"/> 反过来重新装桨 |
| 飞行时间变短，飞机无力 | <input checked="" type="checkbox"/> 电池电量低 <input checked="" type="checkbox"/> 桨装反了 <input checked="" type="checkbox"/> 电池坏了 | <input checked="" type="checkbox"/> 重新给电池充电 <input checked="" type="checkbox"/> 依照电池说明书更换新的电池 |
| 飞舵面不动，或者动作响应较慢 | <input checked="" type="checkbox"/> 舵面、舵角、连接杆、舵机坏了 <input checked="" type="checkbox"/> 连接线坏了或者接头松了 | <input checked="" type="checkbox"/> 更换或者维修坏了的配件 <input checked="" type="checkbox"/> 检查所有连接线，确保所有接头无松动现象 |
| 舵面反向 | <input checked="" type="checkbox"/> 遥控器发射机通道反向 | <input checked="" type="checkbox"/> 检查通道控制（舵面）方向，调试飞机舵面和遥控器的舵面控制杆 |
| 电机无力 | <input checked="" type="checkbox"/> 电机或电池坏了 <input checked="" type="checkbox"/> 电调用了不合适的低压保护装置 | <input checked="" type="checkbox"/> 检查电池、发射机、接收机、电调、电机是否有损坏（如有，请及时更换） <input checked="" type="checkbox"/> 立刻操控飞机降落，重新给电池充电 |
| 接收器的 LED 灯慢闪 | <input checked="" type="checkbox"/> 接收器低电量 | <input checked="" type="checkbox"/> 检查电调和接收器之间的连接 <input checked="" type="checkbox"/> 检查舵机是否受损 <input checked="" type="checkbox"/> 检查连接杆是否安装到位 |

配件列表

| | | | |
|---------|---------|------------|-----------------------------|
| AHRA101 | 机身 | AHDFX002 | 50mm11叶涵道组-不含电机 |
| AHRA102 | 主翼 | AHEDF002 | 50mm涵道组（11叶）-含2627-KV4500电机 |
| AHRA103 | 平尾 | AHSFB002 | 50mm 涵道扇叶 |
| AHRA104 | 座舱 | AHSDX002 | 50mm 涵道筒 |
| AHRA105 | 涵道盖 | AHKVX4500 | 2627-KV4500 电机 |
| AHRA106 | 连接钢丝组 | AHESC003 | 30A 电调 |
| AHRA107 | 螺丝组 | AHSER003 | 9g 塑胶正向舵机 |
| AHRA108 | 舵面摇臂组 | VEC-AH026P | 集成飞控维翼（无外壳） |
| AHRA109 | 舵面摇臂盖组 | | |
| AHRA110 | 机头防摩擦胶件 | | |
| AHRA111 | 机尾防摩擦胶件 | | |
| AHRA112 | 机翼防摩擦胶件 | | |
| AHRA113 | 贴纸 | | |